

EVOLUTION 2 CYGNET

AQUATIC HEATER (ALL TITANIUM)

Supplied with low watts density coiled titanium heating elements. Cygnet heaters are titanium construction and an ideal solution for ponds and tropical marine applications.



FEATURES

- Six power options ranging from 1-kW to 8.4-kW
- Easy installation, fully equipped and pre-wired
- Robust, durable construction
- Ultra-reliable flow switch allows safe operation
- Supplied with temperature thermostat & overheating sensor
- Compact, durable design
- Analogue control with 1.2°C differential or digital control with 0.5°C differential and selectable multi-lingual display
- Titanium flow tube and titanium heating element(s)
- Can be floor or vertically wall mounted
- Vortex, long life, stay clean heating element technology
- 100% efficiency throughout the product life
- Silent operation

TECHNICAL DRAWINGS

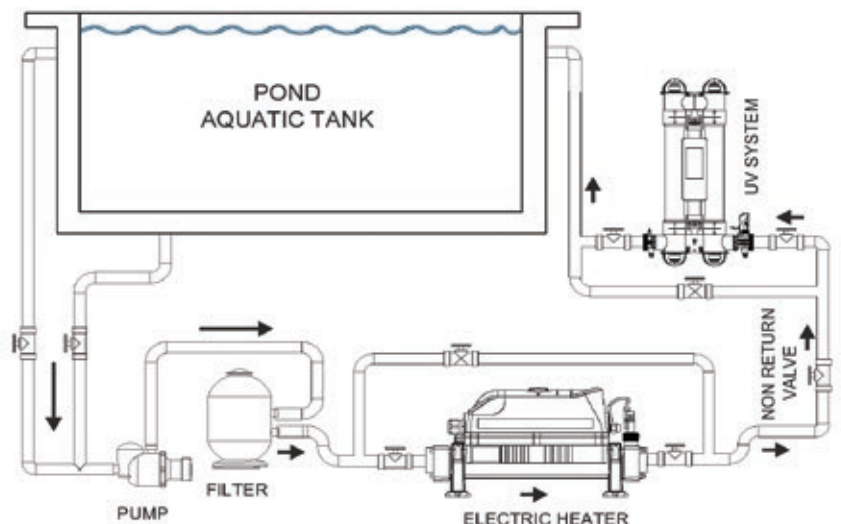
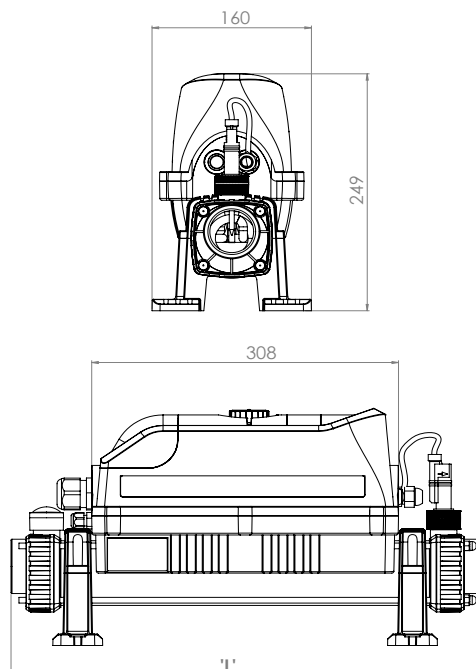

PRESSURE DROP

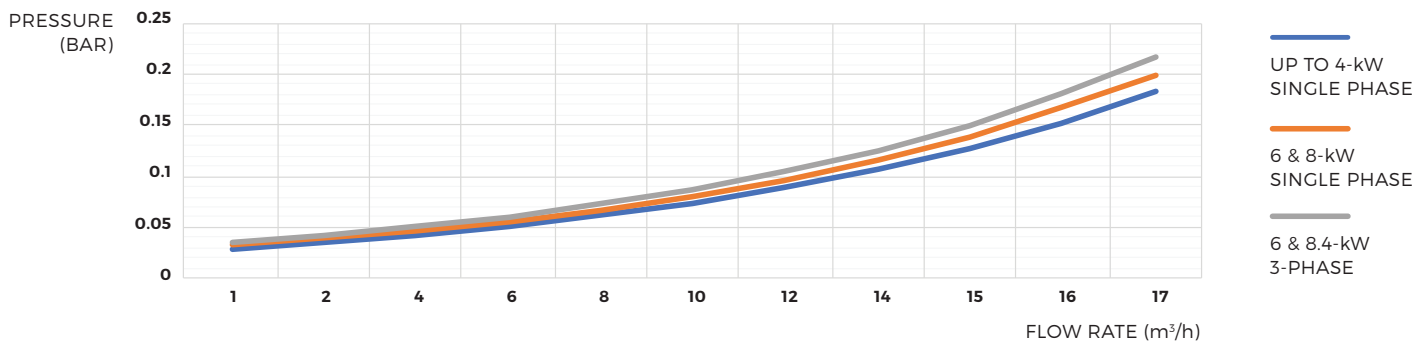

SPECIFICATIONS

POWER SUPPLY	Single phase or three phase
FLOW REQUIREMENTS	Minimum flow: 1m³/h Maximum flow: 17m³/h
HEATING ELEMENTS	Grade 1 titanium
FLOW TUBE	Grade 1 titanium
CONTROL THERMOSTAT	Analogue: 0 > 45°C (1.2°C differential) Digital: 0 > 45°C (0.5°C differential)
SAFETY THERMAL CUT OUT	60°C (manual reset)
FLOW SWITCH	Rhodium tipped reed switch with titanium fulcrum pin
CONTACTORS	Siemens 3RT2023 or 3RT2027
SEALS	High temperature special formula EPDM ferrules, TPE end fitting gaskets
WATER CONNECTIONS	1.5" BSP female thread supplied with 1½" / 50mm stepped ABS unions for rigid pipe and 1½" / 1¼" stepped hose tails for flexible pipe
INTERNATIONAL PROTECTION MARKING	IP44
FREQUENCY	50/60 Hz
WORKING PRESSURE	4 bar maximum
MOUNTING	Floor or wall mounting

MODELS

220-240V 1-PHASE	LOAD	PRODUCT CODES		DIMENSION 'L'	NET WEIGHT	GROSS WEIGHT	VOLUME
		Analogue	Digital				
Power Output	Amp			mm	kg	kg	m³
1-kW	4.5	AQ-E2-1-1	AQ-E2D-1-1	462	3.36	4.90	0.0571
2-kW	8.5	AQ-E2-1-2	AQ-E2D-1-2	462	3.36	4.90	0.0571
3-kW	12	AQ-E2-1-3	AQ-E2D-1-3	462	3.36	4.90	0.0571
4-kW	18	AQ-E2-1-4	AQ-E2D-1-4	462	3.36	4.90	0.0571
6-kW	26	AQ-E2-1-6	AQ-E2D-1-6	462	3.66	5.20	0.0571
8-kW	35	AQ-E2-1-8	AQ-E2D-1-8	592	3.66	5.20	0.0571
400V 3-PHASE *							
6-kW	9	AQ-E2-3-6	AQ-E2D-3-6	592	4.30	5.83	0.0571
8.4-kW	13	AQ-E2-3-8	AQ-E2D-3-8	592	4.30	5.83	0.0571

* for voltages other than 400V please add: -380 or -415 at the end of a product code e.g: E2-3-15-380
For any other voltages or custom builds, please contact our sales team sales@elecro.co.uk